

FLA COE
FLB COE
FLD Conventional
Business Class

Business Class M2
FLC 112 Conventional
> Century Class Conventional
> Argosy COE

Cargo
> Columbia
Condor

Freightliner
Service Bulletin

Description of Revisions: *This service bulletin replaces the original version dated April 2001. This version adds information about the ZF Meritor™ FreedomLine™ transmission. Three figures have been added and Figure 9 has been corrected.*

General Information

The following information is provided to help in determining whether a potential transmission problem is actually the transmission or possibly the Freightliner SmartShift® Transmission Shift Control.

Resistance checks at the SmartShift connector can help determine connection problems.

DataLink Software can be used to test the SmartShift control. The tests require a ServiceLink computer connected to the vehicle. If the tests confirm the shift control is defective, this bulletin also includes connector resistance checks to rule out wiring issues.

Follow the procedures below for Freightliner SmartShift testing using DataLink Monitor and dash displays. If the shift control fails to test correctly, go to the resistance checks under the heading "Shift Control Resistance Checking."

SmartShift Control Checking Using DataLink Monitor (DLM)

1. With the wheels chocked, start the engine.
2. Connect the service computer to the truck and start ServiceLink.
3. Click on the **Applications** button on the bottom left of the screen.
4. Click on **Launch DataLink Templates** icon. An overview of all available templates will be shown.
5. If the vehicle is equipped with Eaton® Fuller® AutoShift™, click on **SmartShift with Eaton AutoShift**. If the vehicle is equipped with ZF Meritor™ SureShift™, click on **SmartShift with Meritor SureShift**.

NOTE: The DLM template for the SureShift transmission will not work with the ZF Meritor FreedomLine transmission. For further diagnostic assistance on FreedomLine transmissions, use Meritor's TransSoft software.

6. Go directly to the appropriate section of this bulletin.

NOTE: To determine which transmission is installed on the vehicle, look on the front of the shift control.

- For Eaton Fuller AutoShift, the four-position selector switch is marked "R-N-D-L." See **Fig. 1**.
- For ZF Meritor SureShift, the three-position selector switch is marked "R-N-F" (older models) or "R-N-D" (newer models). In addition, there is no slide switch. See **Fig. 2**.
- For ZF Meritor FreedomLine, the three-position selector switch is marked "R-N-D." A slide switch is present. See **Fig. 3**.

SmartShift Control Testing for Eaton AutoShift

The AutoShift DataLink Monitor template (**Fig. 4**) will display the current vehicle status and will reflect change in status. Vehicle information is retrieved from the transmission ECU on the databus. The monitor can also be used to verify readings on the instrument panel.

To test the shift control using the datalink, the vehicle can be placed into a mode that allows the gears to be shifted without the engine running. This step explains how to enter that mode.

1. Turn the ignition OFF (engine OFF), then turn the ignition back ON, but don't start the engine. The transmission controller will still be in the 'Engine ON' mode, therefore allowing the gears to be shifted.

Freightliner Service Bulletin

FLA COE
FLB COE
FLD Conventional
Business Class

Business Class M2
FLC 112 Conventional
> Century Class Conventional
> Argosy COE

> Cargo
> Columbia
> Condor

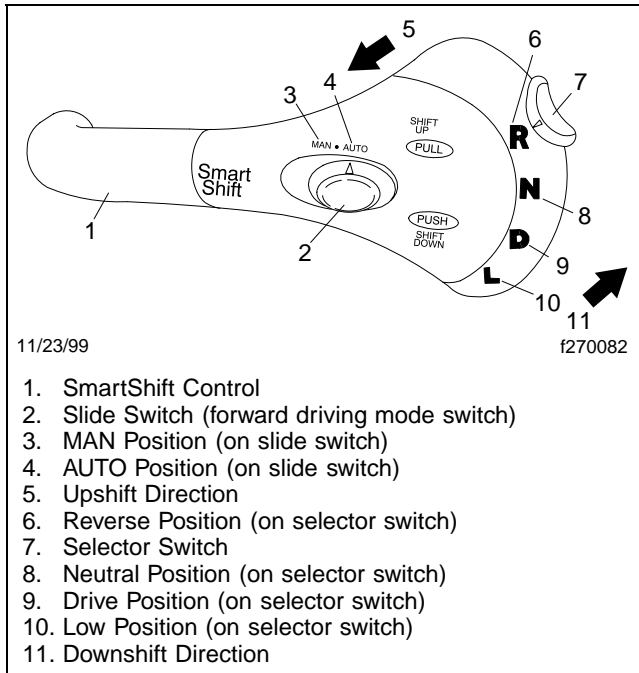

1. SmartShift Control
2. Slide Switch (forward driving mode switch)
3. MAN Position (on slide switch)
4. AUTO Position (on slide switch)
5. Upshift Direction
6. Reverse Position (on selector switch)
7. Selector Switch
8. Neutral Position (on selector switch)
9. Drive Position (on selector switch)
10. Low Position (on selector switch)
11. Downshift Direction

Fig. 1, SmartShift Control (with Eaton Fuller AutoShift)

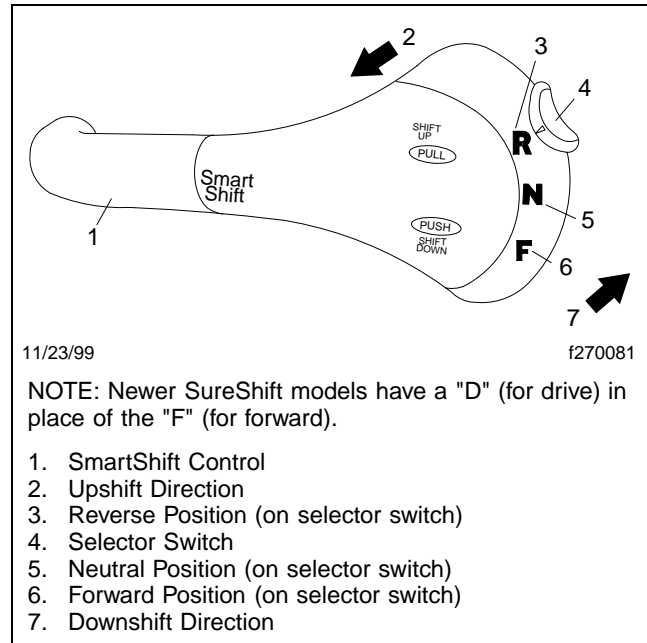

- NOTE: Newer SureShift models have a "D" (for drive) in place of the "F" (for forward).
1. SmartShift Control
 2. Upshift Direction
 3. Reverse Position (on selector switch)
 4. Selector Switch
 5. Neutral Position (on selector switch)
 6. Forward Position (on selector switch)
 7. Downshift Direction

Fig. 2, SmartShift Control (with ZF Meritor SureShift)

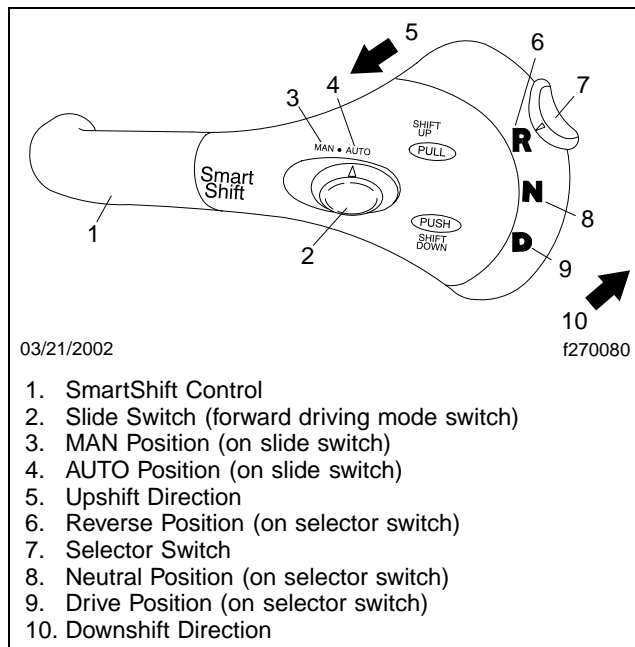

1. SmartShift Control
2. Slide Switch (forward driving mode switch)
3. MAN Position (on slide switch)
4. AUTO Position (on slide switch)
5. Upshift Direction
6. Reverse Position (on selector switch)
7. Selector Switch
8. Neutral Position (on selector switch)
9. Drive Position (on selector switch)
10. Downshift Direction

Fig. 3, SmartShift Control (with ZF Meritor FreedomLine)

2. Test the operation of the shift control for Reverse (R) and Neutral (N).

FLA COE
FLB COE
FLD Conventional
Business Class

Business Class M2
FLC 112 Conventional
> Century Class Conventional
> Argosy COE

Cargo
> Columbia
Condor

**Freightliner
Service Bulletin**

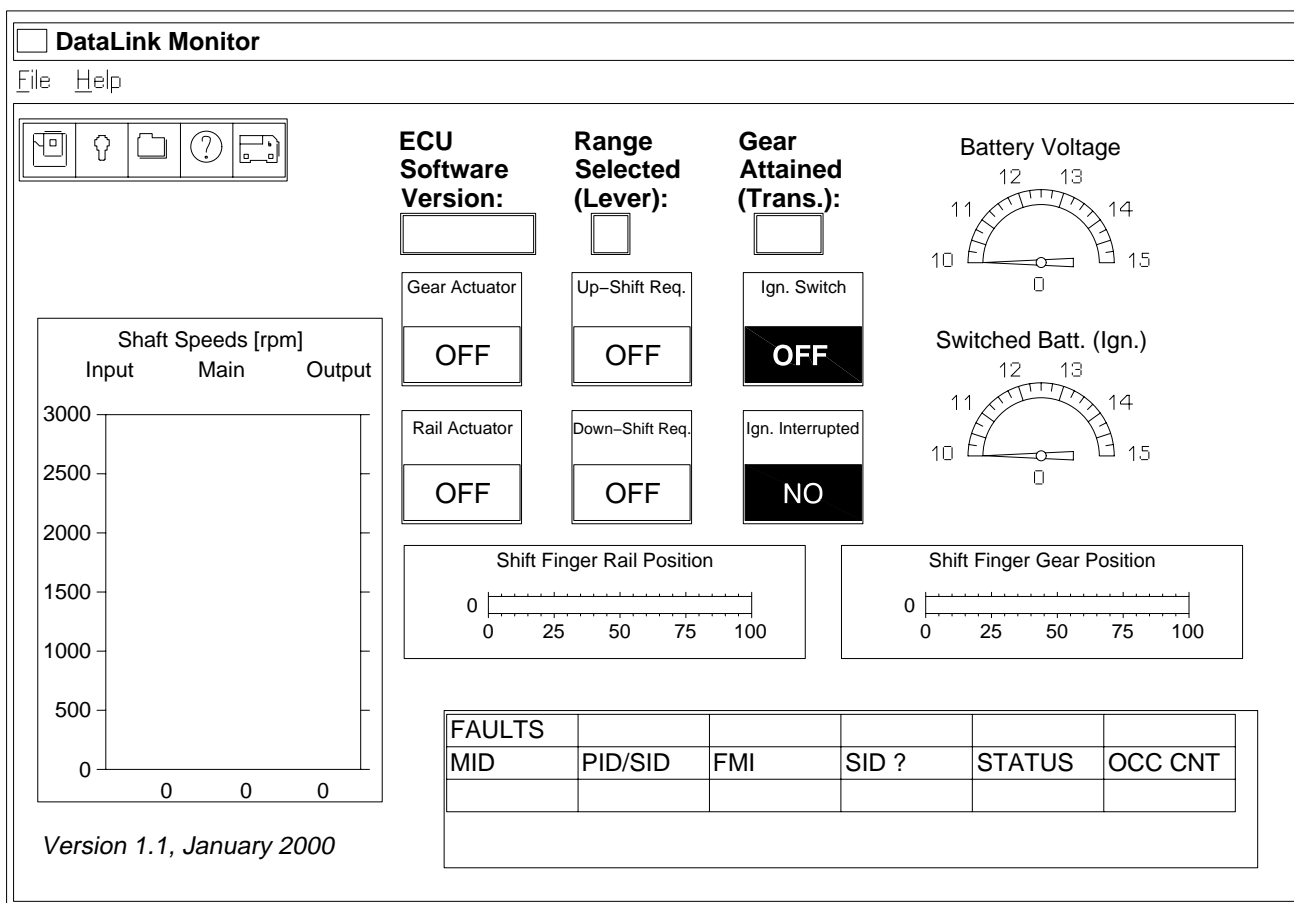

02/19/2001

f610457

Fig. 4, DataLink Monitor Template for Eaton Fuller AutoShift

- 2.1 Select R (Reverse) on the selector switch. In the *Range Selected* field of the template an 'R' should be displayed.
- 2.2 Select N (Neutral) on the selector switch. In the *Range Selected* field of the template an 'N' should be displayed.
3. Test the operation of the shift control for Drive (D).
 - 3.1 Select D (Drive) on the selector switch and turn the slide switch (reading "Automatic/Manual") to Automatic. In the *Range Selected* field of the template, a 'D' should be displayed for Drive.
 - 3.2 With the selector switch still on D (Drive), toggle the slide switch from Automatic to Manual and back. Confirm that the *Range Selected* field shows a 'D' while in Automatic and an 'H' (High) while in Manual.
 - 3.3 While in Manual mode, change the selector switch to L (Low) and confirm that the *Range Selected* field changes from 'H' to 'L.'
4. Test upshifting and downshifting.

Freightliner Service Bulletin

FLA COE
FLB COE
FLD Conventional
Business Class

Business Class M2
FLC 112 Conventional
> Century Class Conventional
> Argosy COE

> Cargo
> Columbia
> Condor

- 4.1 With the selector switch on D (Drive), pull and hold the shift control lever. The *Up-Shift Req.* field will turn green and read 'ON' for 3 seconds.
- 4.2 Push and hold the shift control lever. The *Down-Shift Req.* field will turn green and read 'ON' for 3 seconds.

NOTE: A blinking display indicates that the transmission is attempting to shift into the gear position. A solid display shows the current gear position attained.

5. When the selector switch is in any position but N (Neutral), the *Ign. Interrupt* field on the Monitor template will read 'YES.'

SmartShift Control Testing for ZF Meritor SureShift and FreedomLine

The SmartShift control test for a ZF Meritor SureShift system can be performed by using the dash-mounted gear display. The SureShift DataLink Monitor (DLM) template can be used if further testing of the system is necessary, for example, to confirm dash display readings or gear positions. See **Fig. 5**.

NOTE: The DLM template for the SureShift transmission will not work with the FreedomLine transmission. For further diagnostic assistance on FreedomLine transmissions, use Meritor's TransSoft software.

WARNING

For SureShift transmissions, do not depress the clutch pedal during these tests. Doing so could result in the vehicle moving, possibly causing vehicle damage or personal injury.

Make sure all tires are chocked and the parking brake is set before performing the following tests. These tests require the vehicle to be started and precautions need to be taken to ensure the vehicle will not move.

1. Test the operation of the shift control for Reverse (R) and Neutral (N).
 - 1.1 Move the selector switch to R (Reverse). Confirm that the display is changing from 'N' to 'RL' (Reverse Low), the default reverse gear. The display will change to 'CL' (Clutch) after one second. Please repeat this step if the reading disappeared quickly.
 - 1.2 Pull the shift control lever once to upshift to High Reverse. Confirm the display changes to 'RH' (Reverse High).
2. Test the operation of the shift control for Forward (F) or Drive (D).
 - 2.1 Move the selector switch to F (Forward) or Drive (D).
 - 2.2 Test upshifting and downshifting. Push, then pull, the shift control lever through all the gears and verify that each gear displays correctly on the dash display.

If the display or the DLM template does not confirm the SmartShift control position, the shift control should be tested.

Shift Control Resistance Checking

1. Shut down the engine, apply the parking brake, and chock the tires.
2. Remove the steering column trim panels. See **Fig. 6**.
 - 2.1 Remove the screws securing the panels.
 - 2.2 Separate the forward and rear panels to access the shift control.

FLA COE Business Class M2
 FLB COE FLC 112 Conventional
 FLD Conventional > Century Class Conventional
 Business Class > Argosy COE

Cargo
 > Columbia
 Condor

**Freightliner
 Service Bulletin**

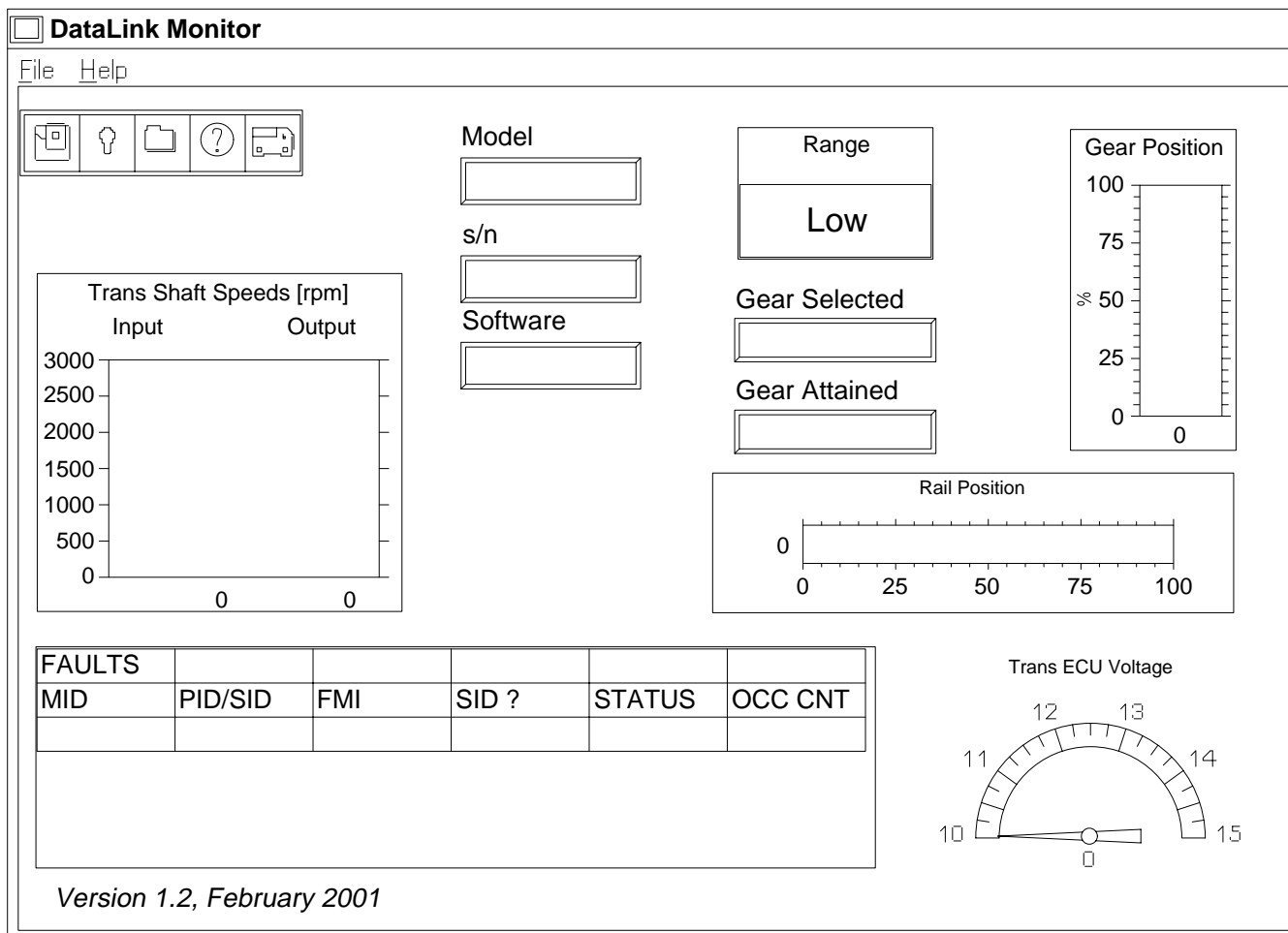

01/11/2001

f610466

Fig. 5, DataLink Monitor Template for ZF Meritor SureShift

3. Disconnect the electrical connector from the plug on the shift control unit. See **Fig. 7**.
4. Assemble the wire extension from the parts in **Table 1** to allow for easy resistance testing.

Parts for Wire Extension		
Part Number	Description	Qty.
PAC12110847	Metri-Pack Terminal	3
PAC12047767	Connector Terminal	3
48-2493-184	18GA GTX Wire, Yellow	3 ft x 3
PAC12047781	3-Pin Connector	1
PAC12047783	Connector Lock	1

Table 1, Parts for Wire Extension

Freightliner Service Bulletin

FLA COE
FLB COE
FLD Conventional
Business Class

Business Class M2
FLC 112 Conventional
> Century Class Conventional
> Argosy COE

> Cargo
> Columbia
Condor

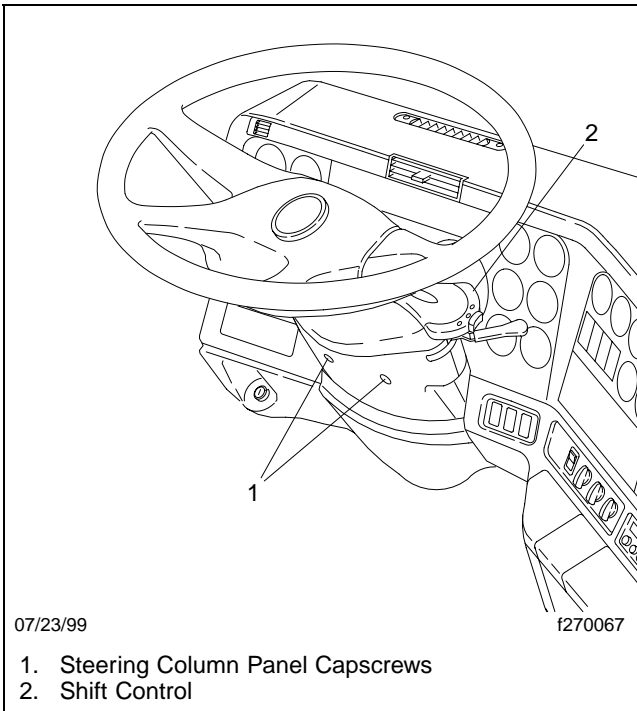

Fig. 6, Steering Column Panel

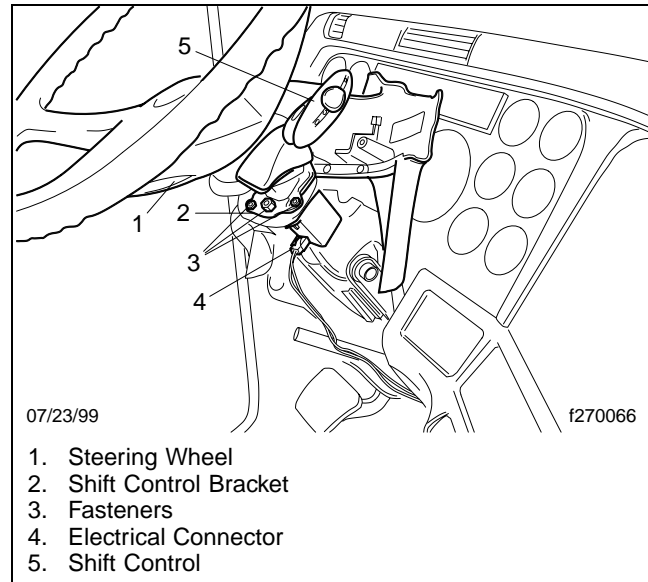

Fig. 7, SmartShift Components

- 4.1 Crimp the connector terminals at the end of each 3-foot (1-meter) wire.
- 4.2 Assemble the 3-pin connector with the connector terminals and connector lock.
- 4.3 Crimp the Metri-Pak terminals on the other end of the wires.
5. Plug the wire extension into the plug on the shift control unit. See **Fig. 8** for SmartShift terminal positions.

NOTE: Using this new wire extension prevents the need to remove the shift control.

6. Check the resistance at the other end of the wires. See **Fig. 9**.
 - Use **Table 2** for a three-position control (R-N-F or R-N-D).
 - Use **Table 3** and **Table 4** for a four-position (R-N-D-L) control.

Parts

Parts are available through the PDCs.

Warranty

This is an informational bulletin only; warranty does not apply.

FLA COE
FLB COE
FLD Conventional
Business Class

Business Class M2
FLC 112 Conventional
> Century Class Conventional
> Argosy COE

Cargo
> Columbia
Condor

**Freightliner
Service Bulletin**

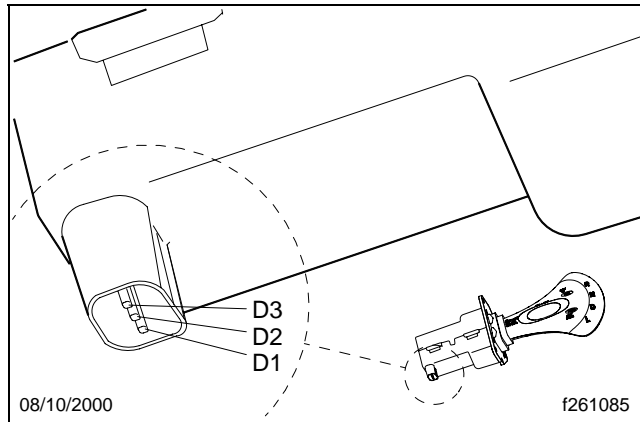
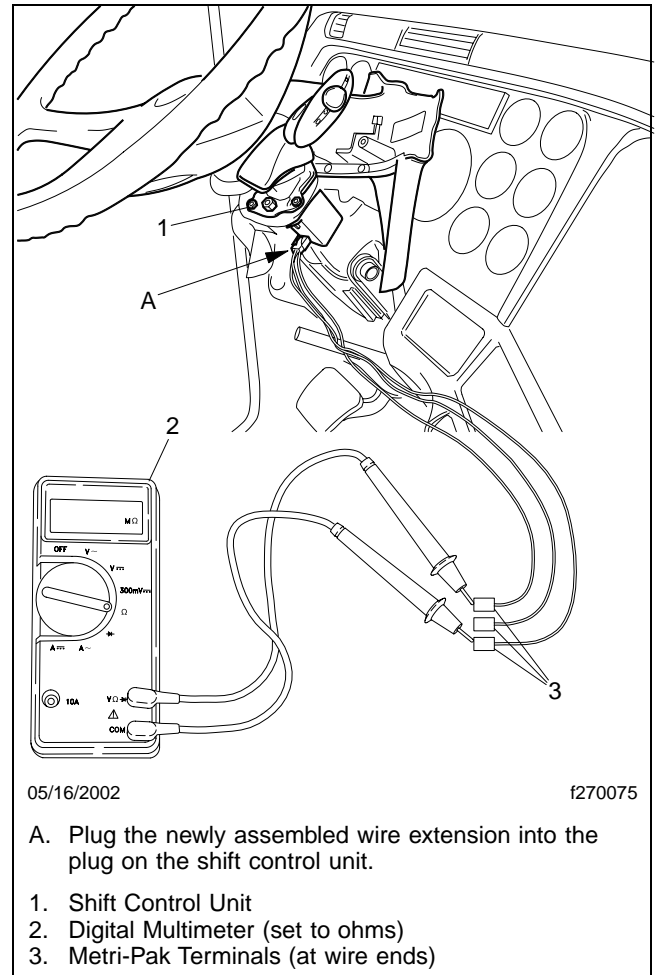

Fig. 8, SmartShift Terminal Positions



- A. Plug the newly assembled wire extension into the plug on the shift control unit.
1. Shift Control Unit
 2. Digital Multimeter (set to ohms)
 3. Metri-Pak Terminals (at wire ends)

Fig. 9, Resistance Checking at Shift Control

Check Resistance on the Three-Position Control at D1 and D3	
Selector Switch + Lever Position	Reading (kOhm)
R	10.2 - 10.6
N	1.65 - 1.71
F or D	2.65 - 2.75
R + Up	4.14 - 4.3
R + Down	6.07 - 6.31

Table 2, Check Resistance on the Three-Position Control at D1 and D3

Check Resistance on the Four-Position Control at D2 and D3	
Selector Switch Position	Reading (kOhm)
R	2.947 - 3.067
N	0.347 - 0.361
D	0.606 - 0.630
L	1.65 - 1.72

Table 3, Check Resistance on the Four-Position Control at D2 and D3

Check Resistance on the Four-Position Control at D1 and D3	
Slide Switch + Lever Position	Reading (kOhm)
Manual	2.865 - 2.981
Manual + Up	0.531 - 0.553
Manual + Down	1.150 - 1.197
Auto	11.27 - 11.73

Table 4, Check Resistance on the Four-Position Control at D1 and D3